



**BMH 480**  
WITH H600  
ATTACHMENT





## ENGINE

Engine	Volvo TAD1353VE
Power	345 kW / 469 HP
Displacement	12.8 l
Max. torque	2380 Nm
Fuel tank	850 l

## TRANSMISSION

Hydraulic pumps and motors	Bosch Rexroth
Max. speed	5 km/h (3.10 mph)

## UNDERCARRIAGE

Undercarriage type	D5		
Grouser shoes	dual blade		
	Grouser (mm/in)	Total width (mm/in)	Track width (mm/in)
D5:	600/24	2600/102	2000/79

## OPTIONS

Bunker capacity 25 m<sup>3</sup>  
Maximum load control  
Fire extinguishing system  
GPS system  
Internal or external refuelling unit  
Centralised lubrication system  
Radio  
LED working lights  
etc.

## ATTACHMENTS

H600	5240 kg (11773 lbs)
Rotor	28 x HDT
Rotor diameter	600 mm (23.6 in)
Working width	2300 mm (90.6 in)
Total width	2830 mm (111.4 in)

## WEIGHT AND MOBILITY

with H600	28200 kg (62170 lbs)
without H600	22900 kg (50456 lbs)
Ground pressure	555 g/cm <sup>2</sup>
Gradeability sideways	30°
Gradeability frontal	30°

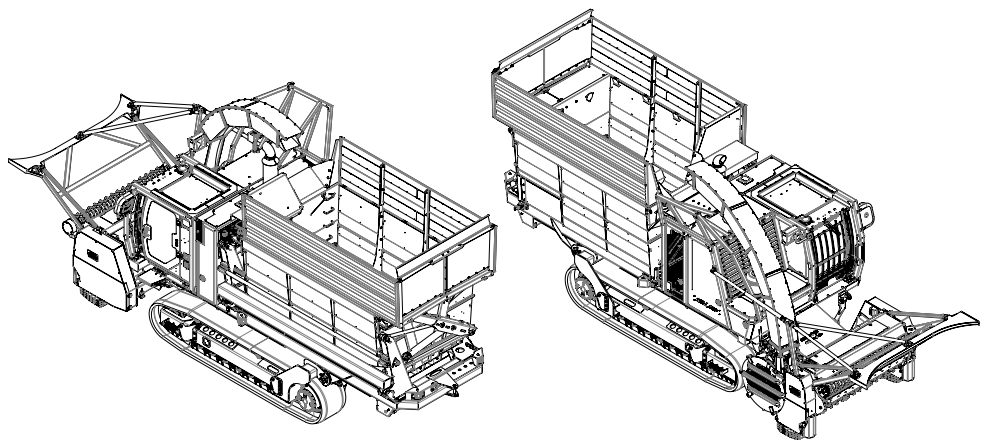
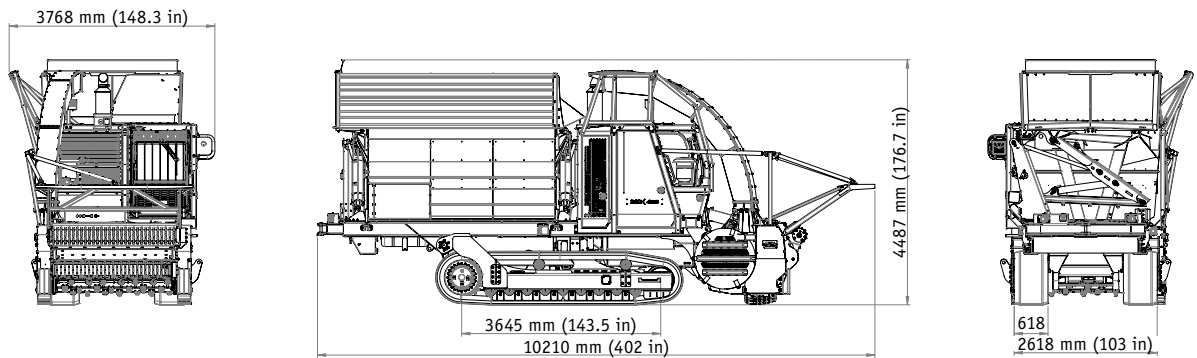

## TECHNICAL DATA

**Prinoth**